

Rail King Model RK320 G4

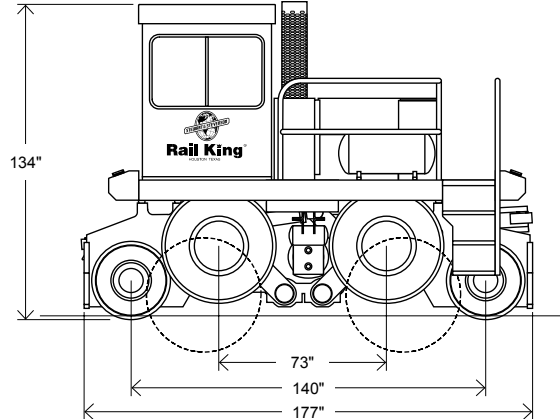
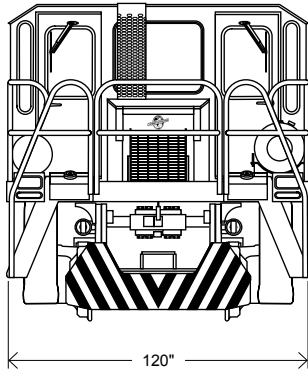

SPECIFICATIONS

GENERAL

Weight	49,000 lb
Length	177"
Width	120"
Height (on road)	142"
Height (on rail)	134"
Rail Clearance	3"
Road Clearance	10"
Speeds (Forward & Reverse)	4
On road	9 mi/h
On rail	15 mi/h

ENGINE

Make	Cummins
Model	QSB 6.7
Type	Electronic, 4-cycle, turbocharged diesel
Rated Power	190 hp @ 2200 rpm
Fuel Tank	40 gal
Features	Tier III compliant

MAXIMUM TRACTIVE EFFORT

When both couplers are used	48,600 lb
When one coupler is used	32,400 lb

Frame

Heavy-duty, welded from 2" steel plate

Muffler

Sound-attenuating, spark-arresting with safety shield, raincap

Transmission

John Deere DF150 with torque converter, four speeds forward and reverse, autoshift or powershift selection

Rail- & Road-Drive

John Deere spiral bevel gear set; designed for bi-directional operation, no spin differential with internal planetary axles. Friction drive transmitted from rail-drive axle incorporates separate braking system. Does not require special tires. Rail shock absorption system standard.

Brakes

Inboard multiple wet-disk brakes. Protected from contaminants and can last up to four times longer than dry-disc brakes. Spark-free for regulatory compliance in hazardous environments.

Railwheels

28" diameter heat-treated cast steel. Tapered tread contour to AAR specifications.

Roadwheels

Heavy duty rock lug industrial tires.

Pneumatic System

High capacity 50-cfm air compressor system. Includes two compressors, three reservoirs with drains, air dryers, lever operated pressure control valve with emergency stop capability.

Power Steering

Full hydrostatic power steering.

Couplers

Two weight-transfer couplers made from fabricated steel (no castings). Couplers slide on high-density self-lubricating nylon bearings for long life and minimal maintenance. This heavy-duty coupler system operates on a center pivot housed in a massive synthetic rubber cushion pressed into both sides of the frame.

Sanders

Replaceable steel sandboxes and eight air-operated sanding tubes with easy clean receivers: two for each rail wheel, front and back.

Full-width Cab

Provides excellent visibility down both sides of the railcar when negotiating curves. Standard equipment includes dual controls, two seats, front and rear wipers, heater, two defrost fans and tempered safety glass, foot and hand throttle and brake actuators.

Controls

Improved console with electric switches to implement functions at each operating position. Instrument panel positioned for viewing ease of operator.

Other Features

Air blast horn and protect-o-seal fuel cap.

Contact us today.

Stewart & Stevenson Rail King

Telephone: 713-679-6525

Facsimile: 713-671-6386

www.railking.net

email: railking@ssss.com

8787 East Freeway

Houston, TX 77029

Rail King[®]
MOBILE RAILCAR MOVER

4 OPERATOR COMFORT SYSTEM
Royalglide



A Century of Innovation

10-07-023 ©2010 Stewart & Stevenson Visit us at www.stewartandstevenson.com.

All data subject to change without notice. The information in this bulletin is believed to be accurate but all recommendations are made without warranty, since the conditions of use are beyond Stewart & Stevenson's control. Stewart & Stevenson disclaims any liability in connection with the use of this information, and does not warrant against infringement by reason of the use of any of its products in combination with other material or in any process. Stewart & Stevenson warrants only that the product complies with specifications agreed to in contracts of sale.